

Installation Manual

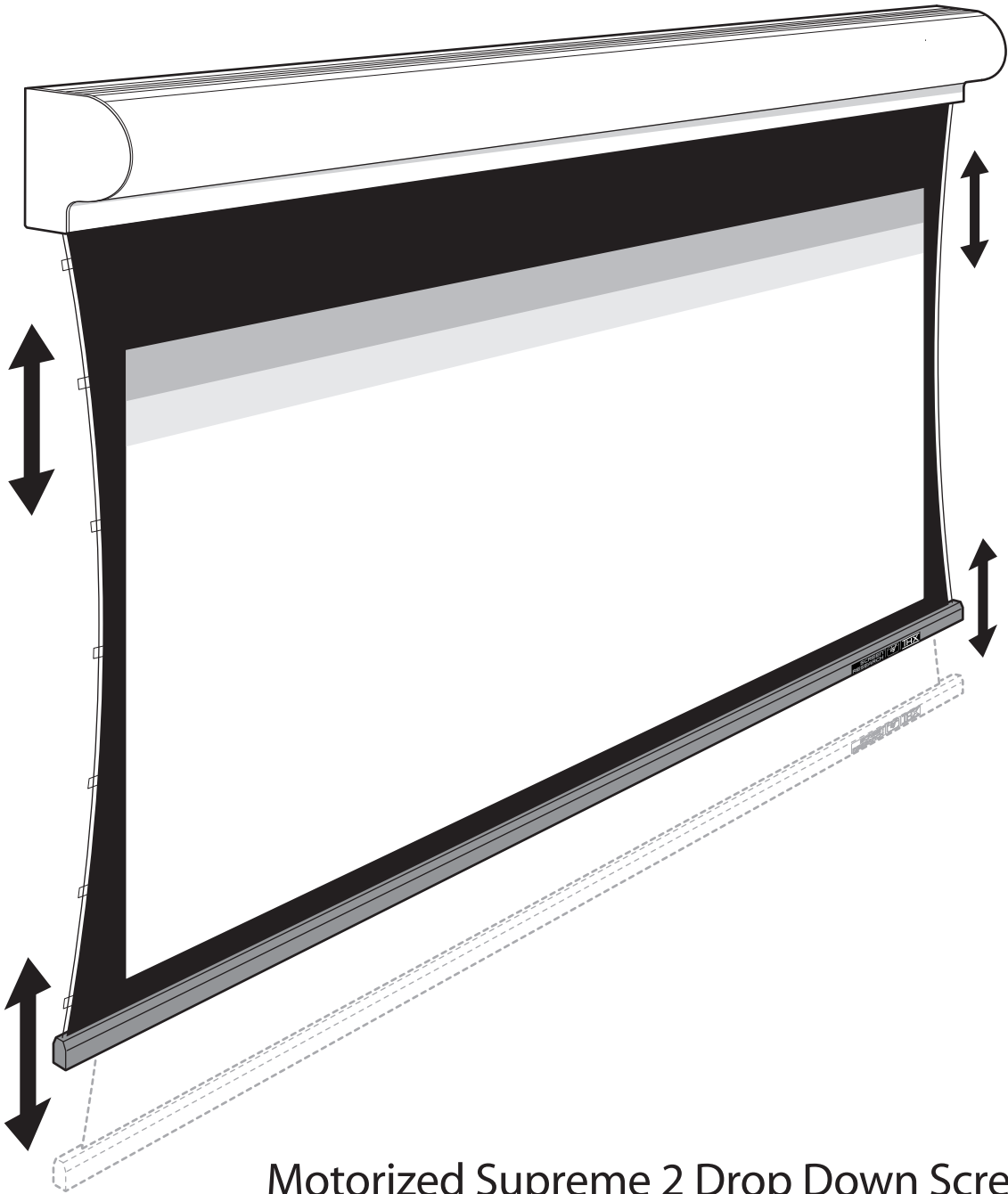

Motorized Supreme 2 Drop Down Screens
On-Ceiling / On-Wall Mounting
with **TFX™** Floating Tab-Tensioning

 **Please read this manual before starting work.** 

Tools & Storage	1
Model Mounting Options	1
Ceiling Mounting	2
Wall Mounting	2
Removal of Velcro Transit Straps (MMS2 Models only)	3
Screen Casing Mounting	4
Screen Transit Locking System Removal - step 1	5
Manual Switch Connection	5
Manual Deployment of the Screen	5
MS2 Models Transit Locking System Removal - step 2 - Black Backing	6
MMS2 Models Transit Locking System Removal - step 2 - Black Backing & Horizontal Masking	6
MMS2 Models Transit Locking System Removal - step 2 - Black Backing & Lateral Masking	7
End Travel Verification (Default set at factory)	8
MCS Installation	8
MCS Configuration - Testing	8
Slot Aperture End-plate Fitting	9
End Cap Fitting	9
Tab-tensioning Bar Adjustment	9
Manual adjustment of motor end-stops	10
Warranty	11
Legal Information	12

Note :
Recommendations on minimum clearance for wall or ceiling mounting

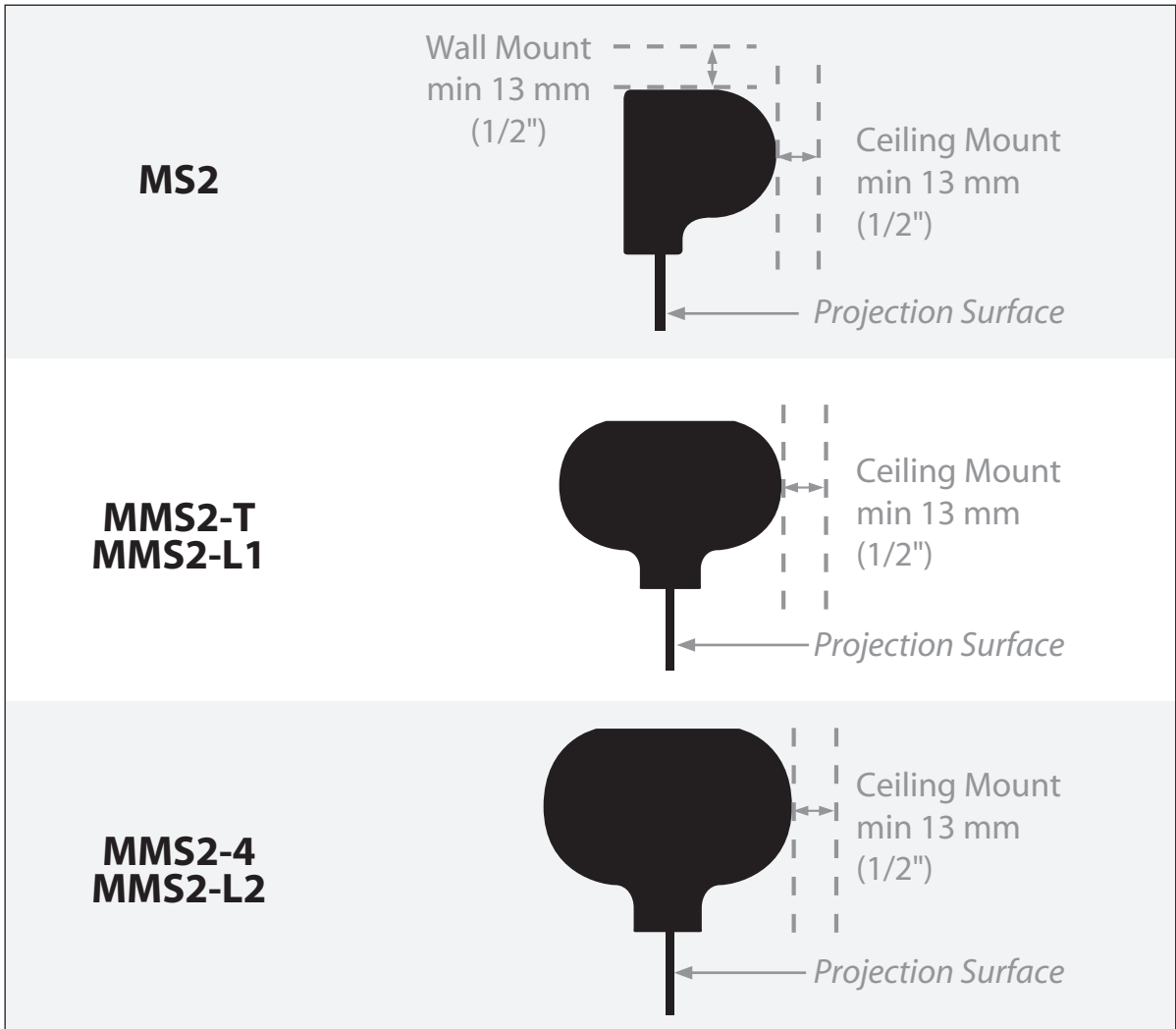

Leave sufficient room to allow access to the end of the screen casing

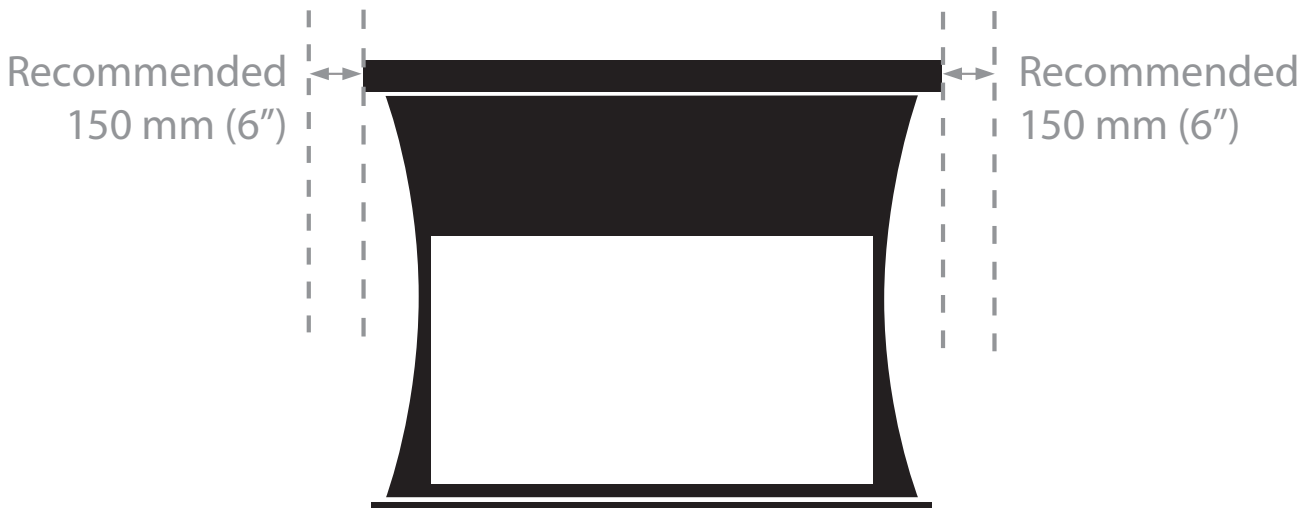

Tools & Storage

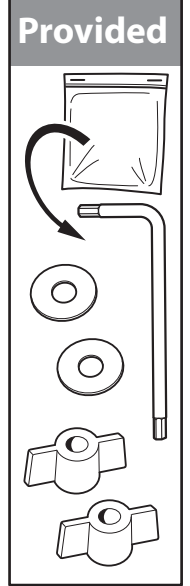
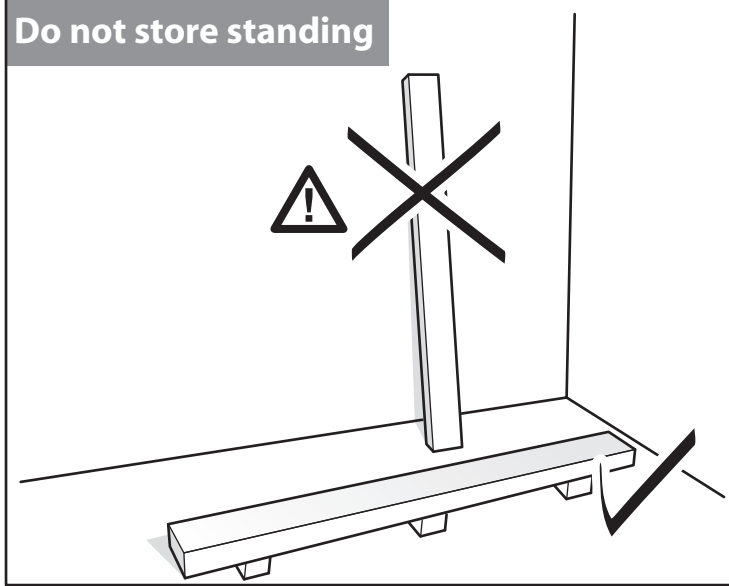

MS2 (80-100")

MS2 (100-120")
MMS2 (80-100")

MS2 (120-160")
MMS2 (100-160") **& / or**

MMS2-4/L2 (All sizes)

Model Mounting Options

MS2

This model has **two** mounting options :

Ceiling Mounting **Wall Mounting**

MMS2

This model has **one** mounting option :

Ceiling Mounting

Ceiling Mounting

1

L-20 mm (13/16")

MS2 or MMS2 models

Model	Casing	Bracket Holes per Bracket	Mounting Brackets Included
MS2	A	6 x Ø8 (5/16")	2
MS2	B	6 x Ø8 (5/16")	3
MMS2	AA	6 x Ø8 (5/16")	3
MMS2	BB	6 x Ø8 (5/16")	3

6 x Ø8 mm (5/16")

220

15 mm (9/16") max

6.5 mm (1/4") max

6.5 mm (1/4") max

Ensure the head of your chosen fixing system fits within the indicated zone.

Use fixings appropriate to your installation construction

Leave sufficient room to allow access to the end of the screen casing - Recommended 150mm (6")

Wall Mounting

2

keep some free space here 35 mm (1 3/8")

L-20 mm (13/16")

MS2 model only

6 x Ø8 mm (5/16")

220

6.5 mm (1/4") max

15 mm (9/16") max

6.5 mm (1/4") max

Use fixings appropriate to your installation construction

Ensure the head of your chosen fixing system fits within the indicated zone.

3 FOR MODELS WITH MASKING ONLY (MMS2)



Cut every orange collars on each transit security fixing !

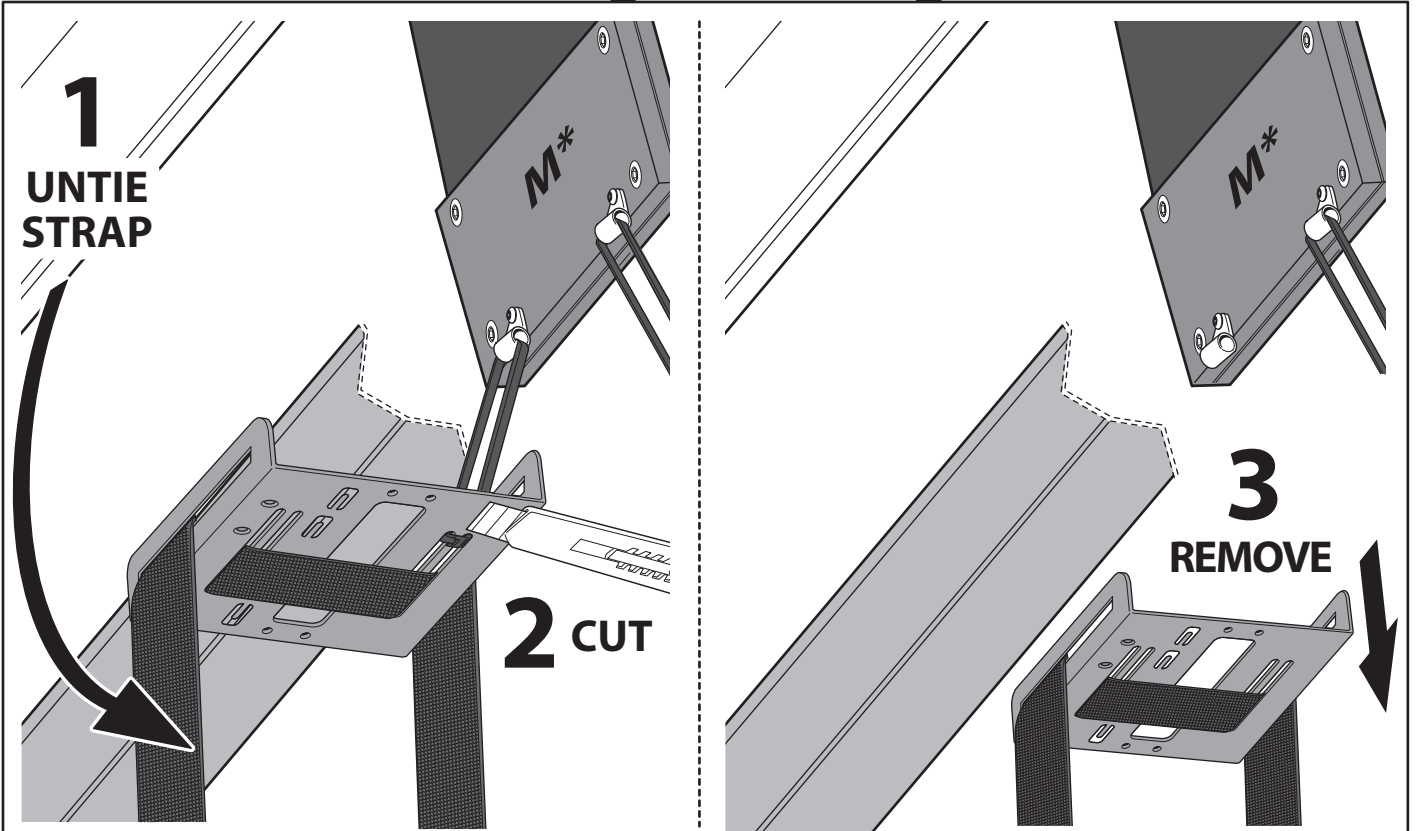
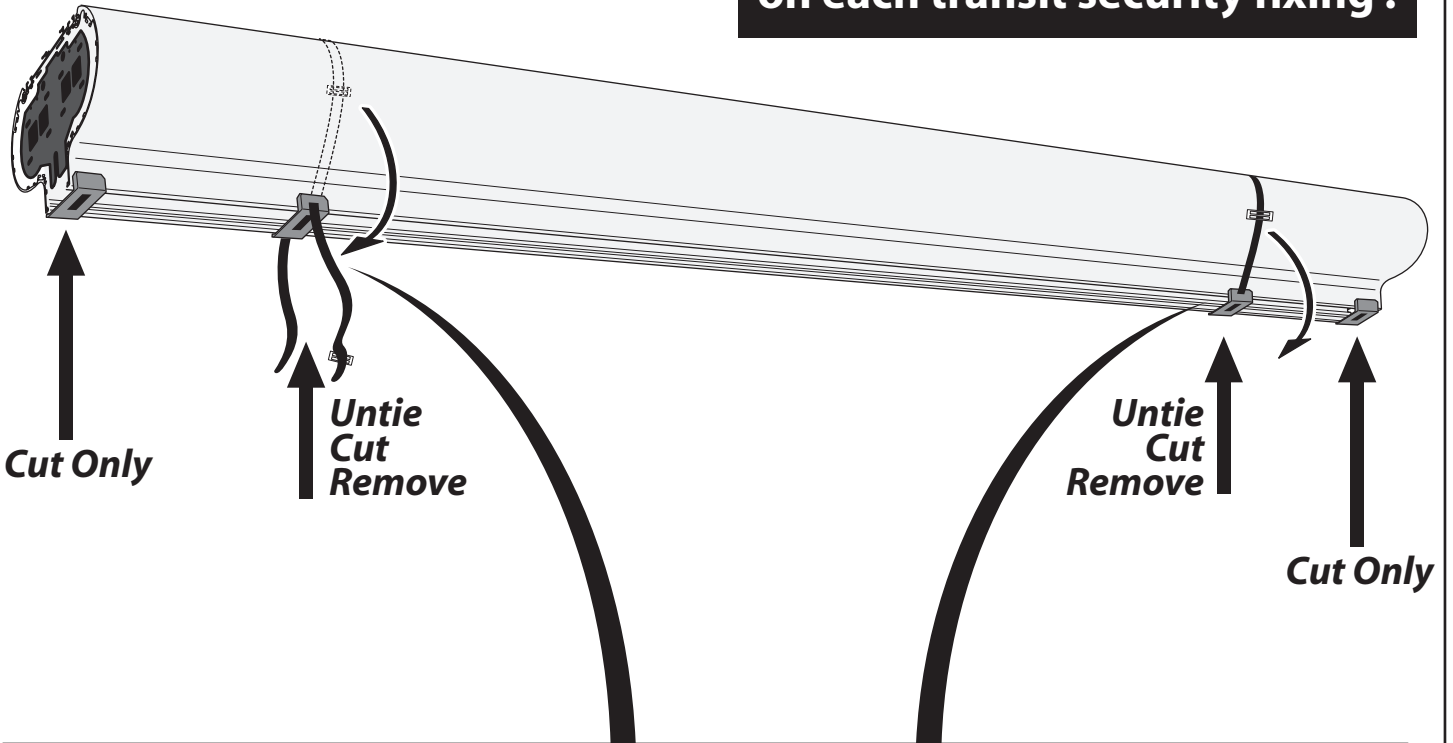

* M (Lateral Masking) may not be present on your screen.

CAUTION : keep all the transit security fixings for any future transportation

Screen Casing Mounting

4

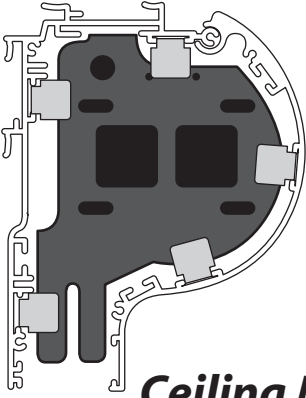
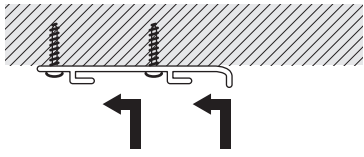

Ceiling Mounting

MS2

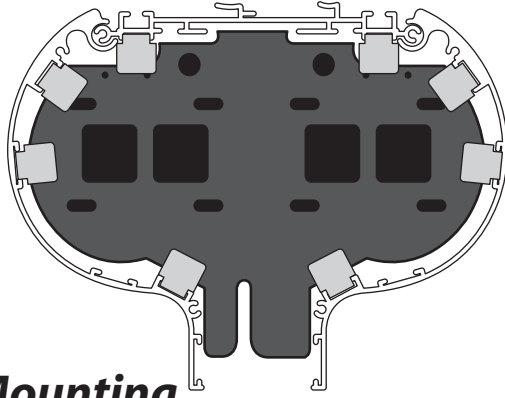
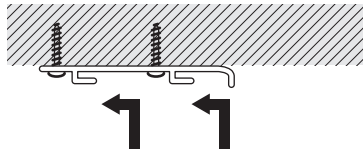

MMS2

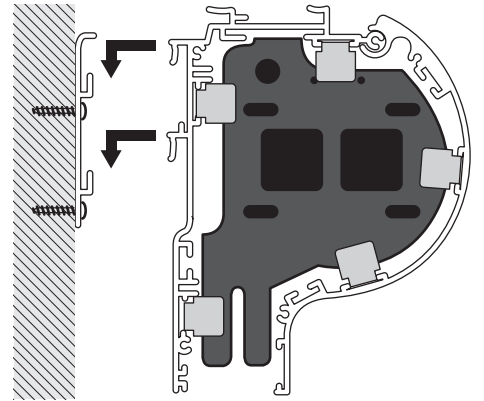

Wall Mounting

MS2

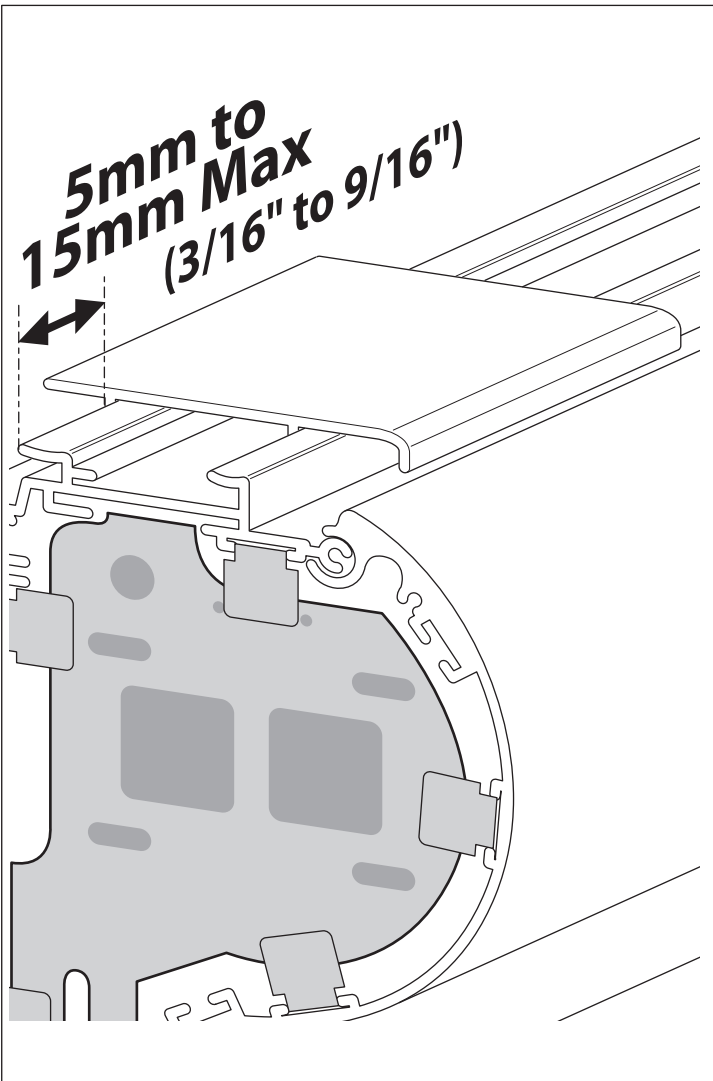

MS2

Ceiling Mounting

Wall Mounting

MMS2

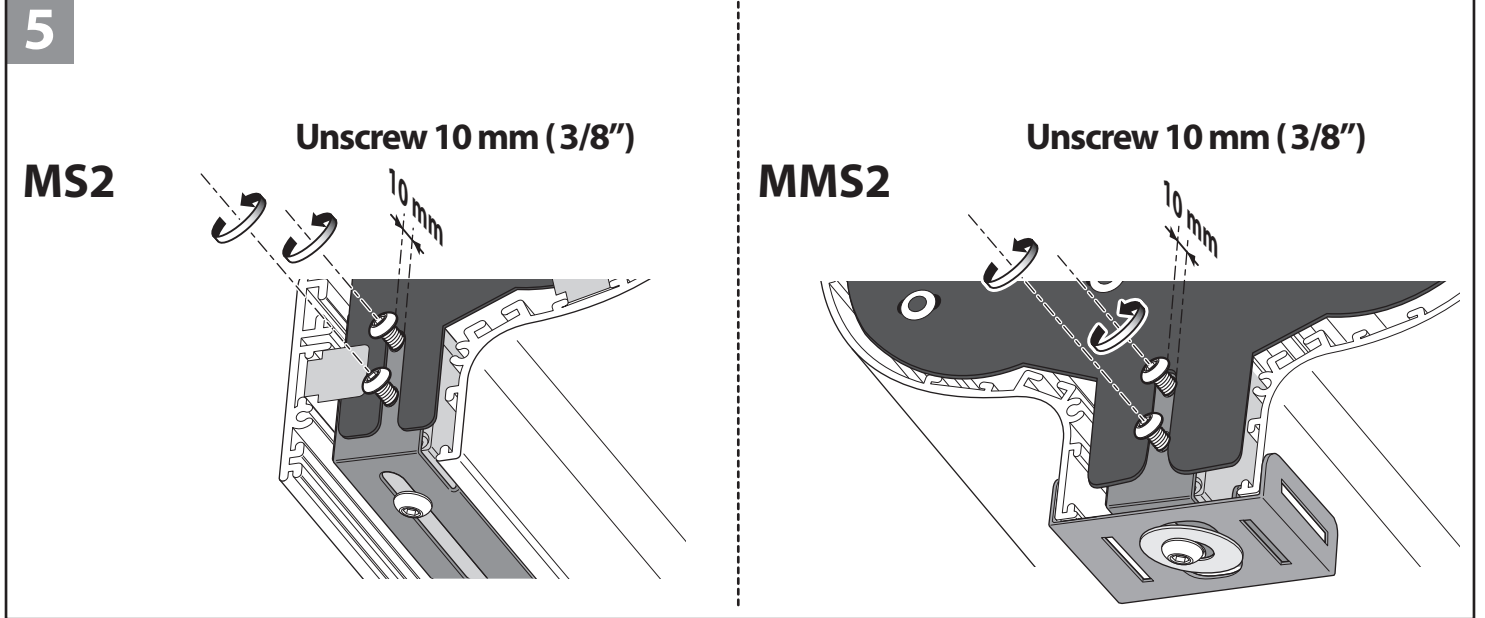

Manual Switch Connection

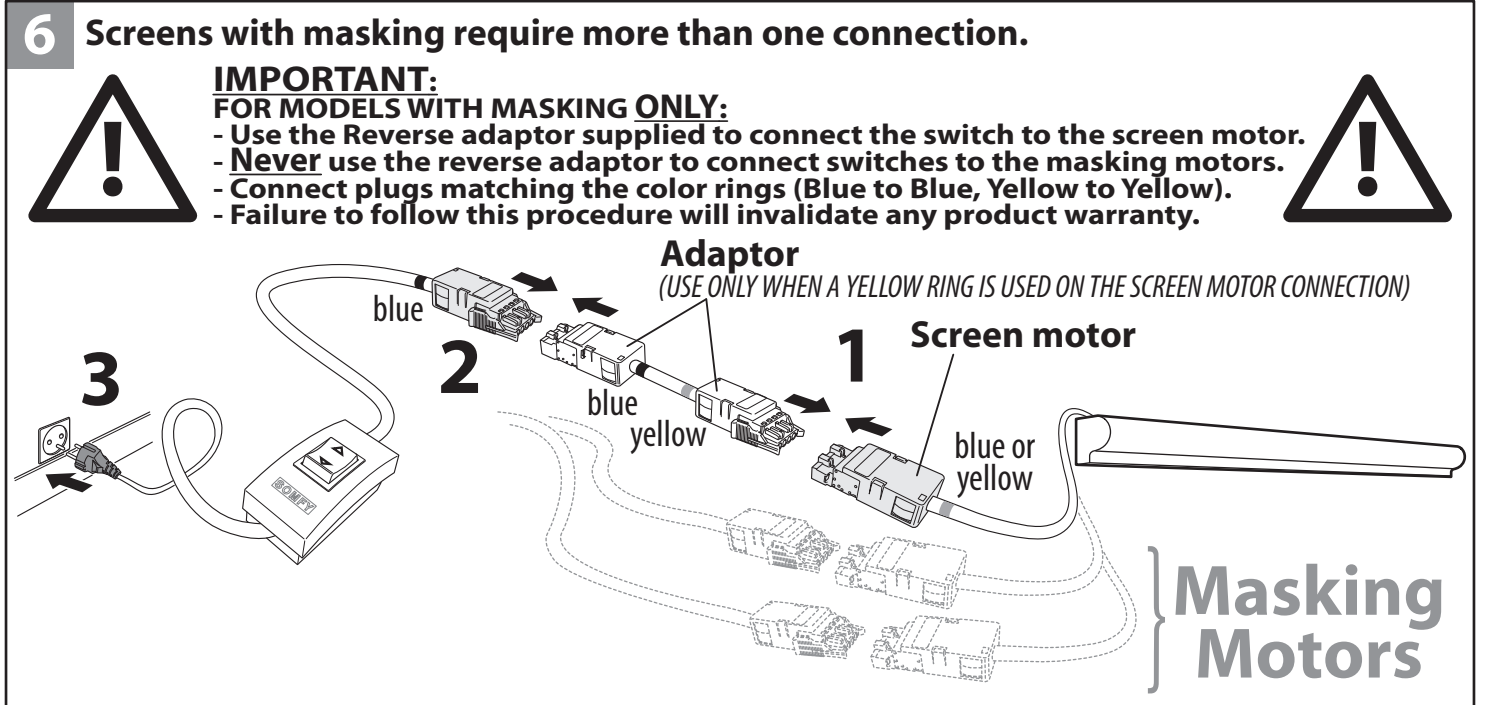

Manual Deployment of the Screen

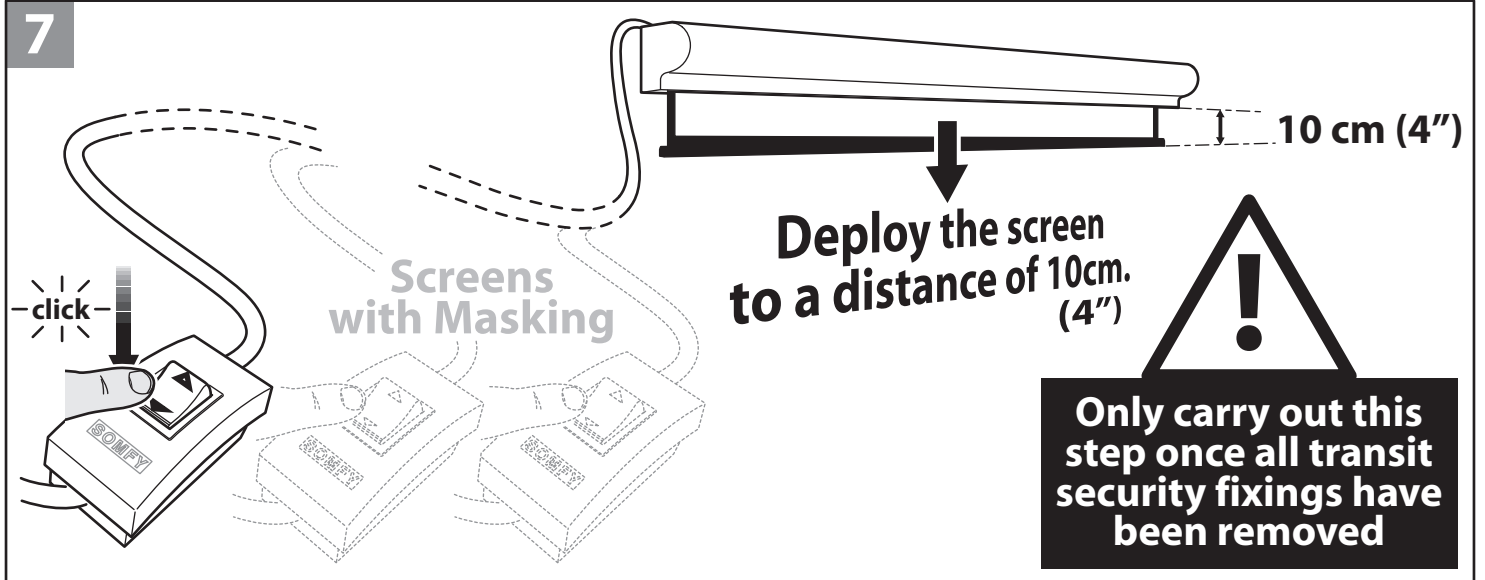

MS2 Models Transit Locking System Removal - step 2 - Black Backing

**8 MS2
Only**

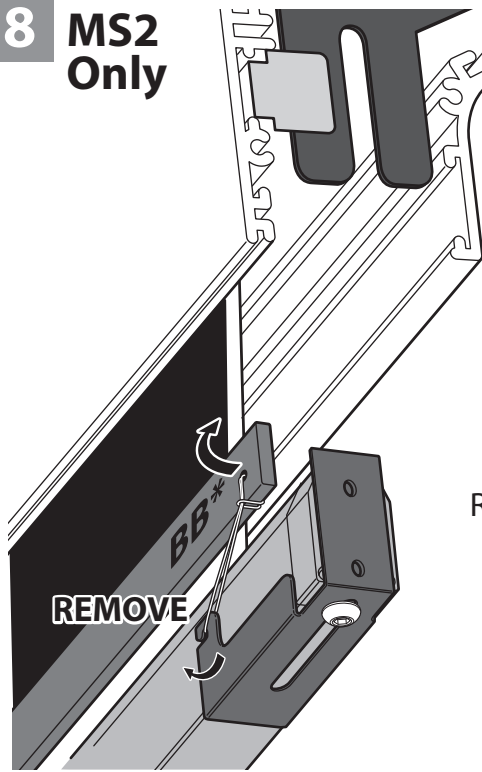

Repeat at each end of the screen.

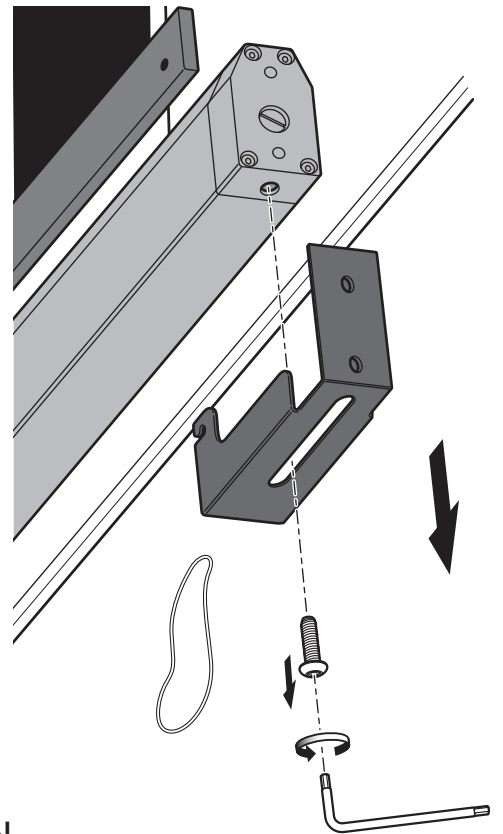

* **BB** (Black Backing) Layer may not be present on your model.

MMS2 Models Transit Locking System Removal - step 2 - Black Backing & Horizontal Masking

8 MMS2 Repeat these steps at each end of the screen.

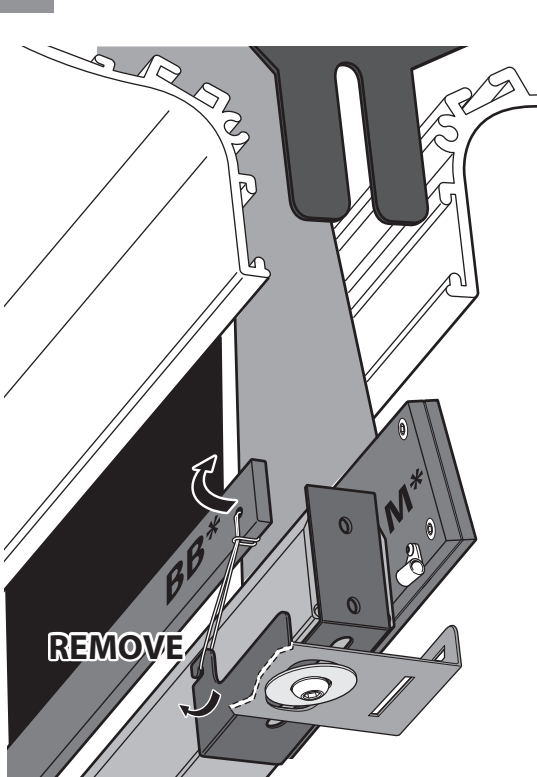

**Horizontal
Masking**

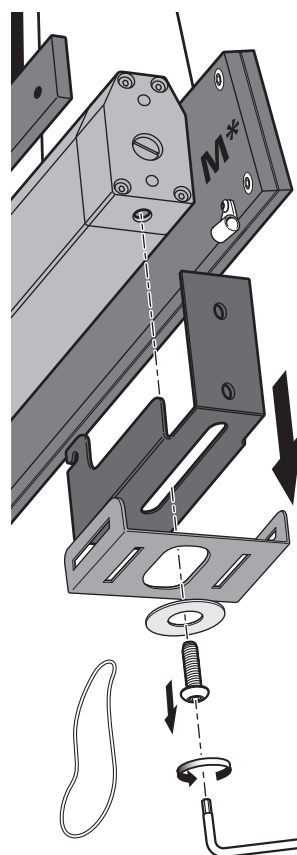

REMOVE

**Horizontal
Masking**

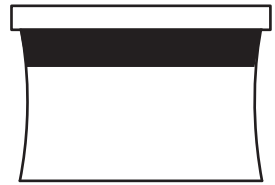

REMOVE

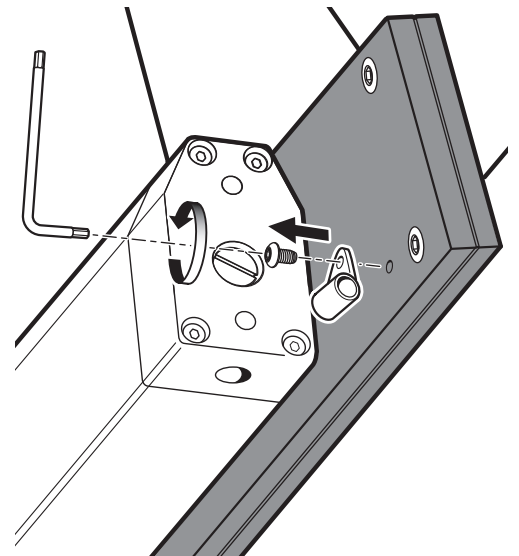

* **BB** (Black Backing) Layer may not be present on your model.

* **M** (Horizontal Masking) may not be present on your screen.

8 MMS2

**Lateral
Masking**

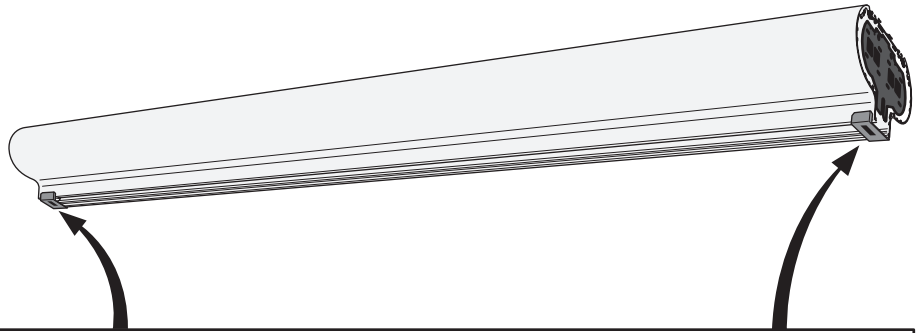
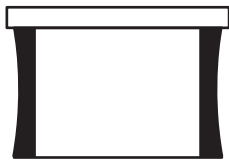

1

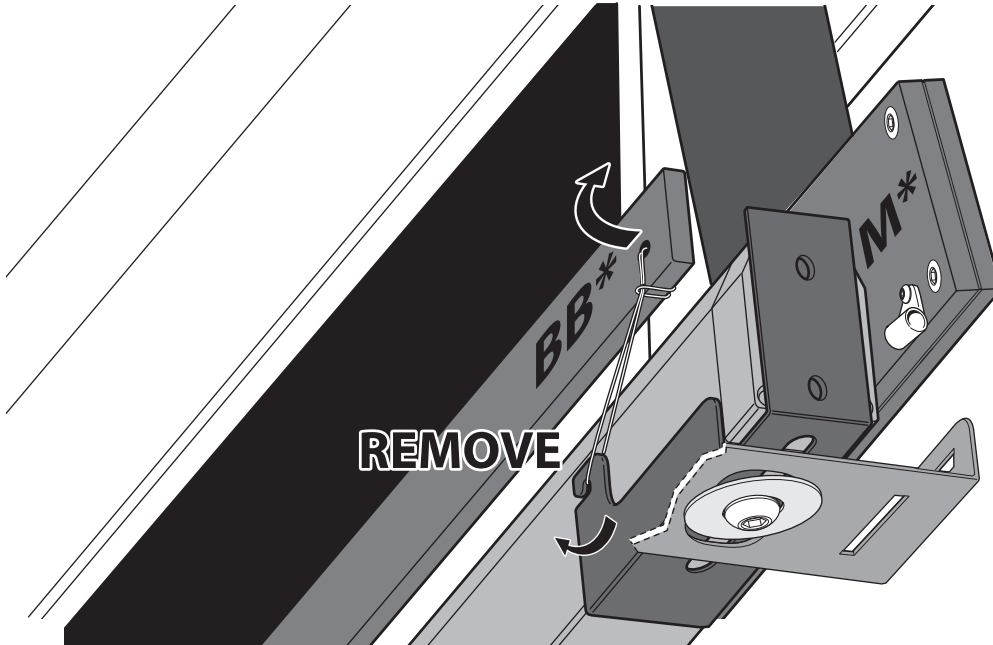

2

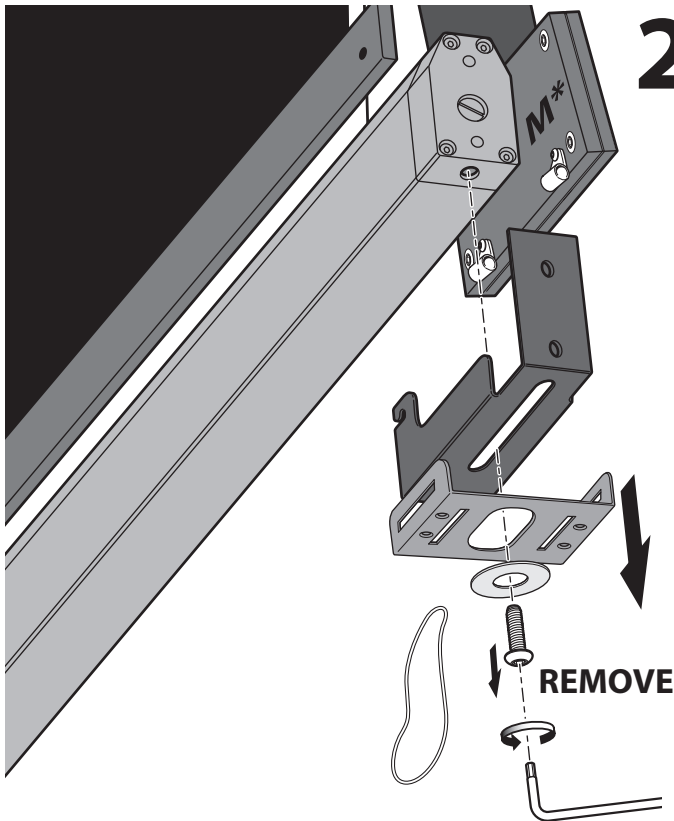

3

**Lateral
Masking**

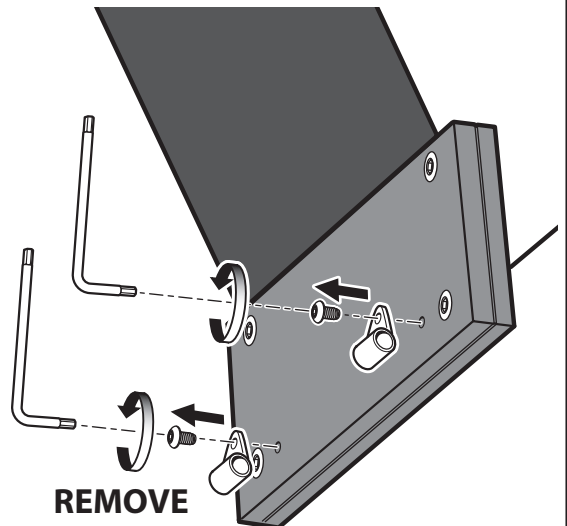
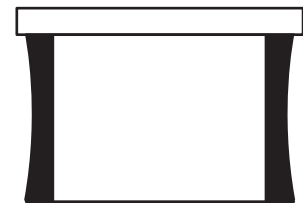

* **BB** (Black Backing) Layer may not be present on your model.
* **M** (Lateral Masking) may not be present on your screen.

End Travel Verification (Default set at factory)

9

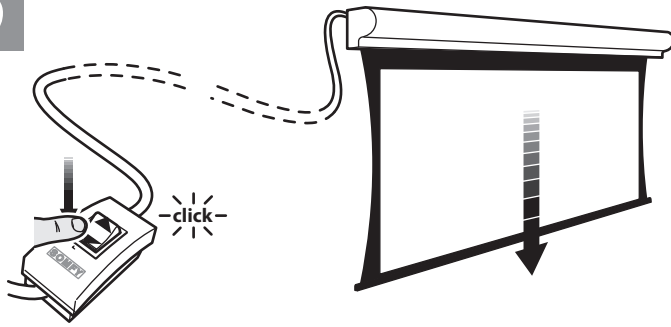

- **Carefully** deploy the screen to its maximum extent.
- Verify that it stops automatically at the desired end of travel.
- If this is not the case, please proceed to Step **15**

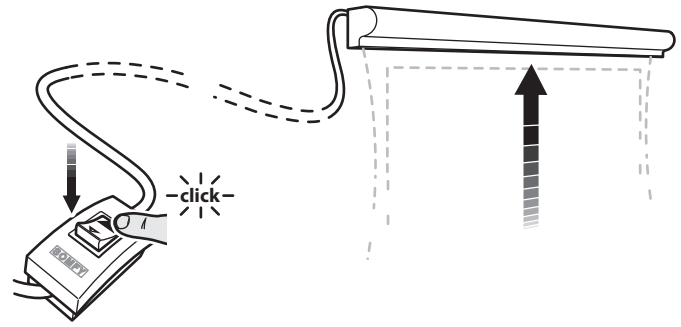

- **Carefully** stow the screen to its stored position.
- Verify that it stops automatically at the desired end of travel.
- If this is not the case, please proceed to Step **15**



Do not pass the white line drawn in the black drop zone. After this point, deployment of the fabric risks damage to the product.



Important : As part of the installation procedure it is important that the motor end stops are verified in order to prevent damage to the screen. The end stop limits are set at the factory, but may have been released during shipping. Failure to perform this procedure will void any subsequent claims made under the product warranty. Please contact Screen Research if you have any questions.



Perform this step for all motors/masks !

MCS Installation

- 10** Refer to the MCS hardware guide in order to connect your control devices correctly.

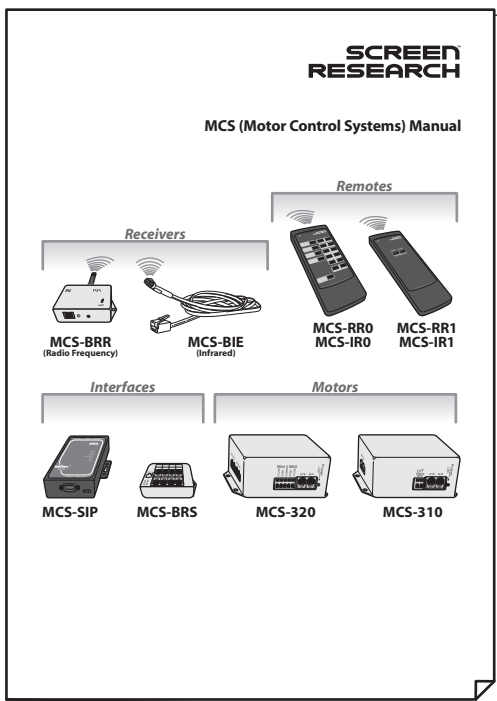

MCS Configuration - Testing

- 11** Refer to the MCS software guide should you wish to reprogram the motor control system.

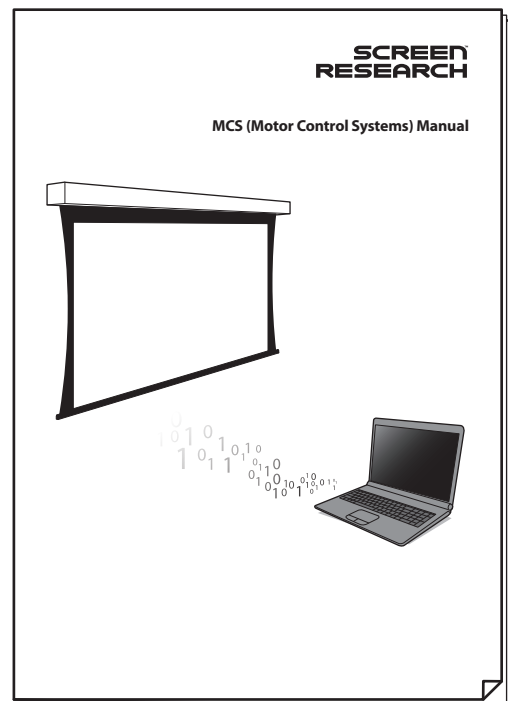

Slot Aperture End-plate Fitting

12

Press fit

Step only applicable if the slot aperture has not been fixed to then end cap at the factory

End Cap Fitting

13 Magnet attachment...

...and screwing.

TIPS : Deploy the screen to a distance of 10 mm (4") to increase the accessibility to the threaded rod.

Tab-tensioning Bar Adjustment

14 Deploy the screen to its standard operating position before adjusting the tab-tensioning system.

1 Insert & push

2 Adjust

Gently move the bar from side to side to establish whether the inner bar is floating free

Good : Inner bar is floating..... ✓

Bad : Inner bar is too low..... ✗

Bad : Inner bar is too high..... ✗

Manual adjustment of motor end-stops

15 Please, follow this step **ONLY** if the end of travel of the motors has moved during transit. If your screen automatically stops at the desired full extension and full winding up, you do **NOT** need this step.

1 - Using a screwdriver, push the two buttons in order to free the screen stopping positions.

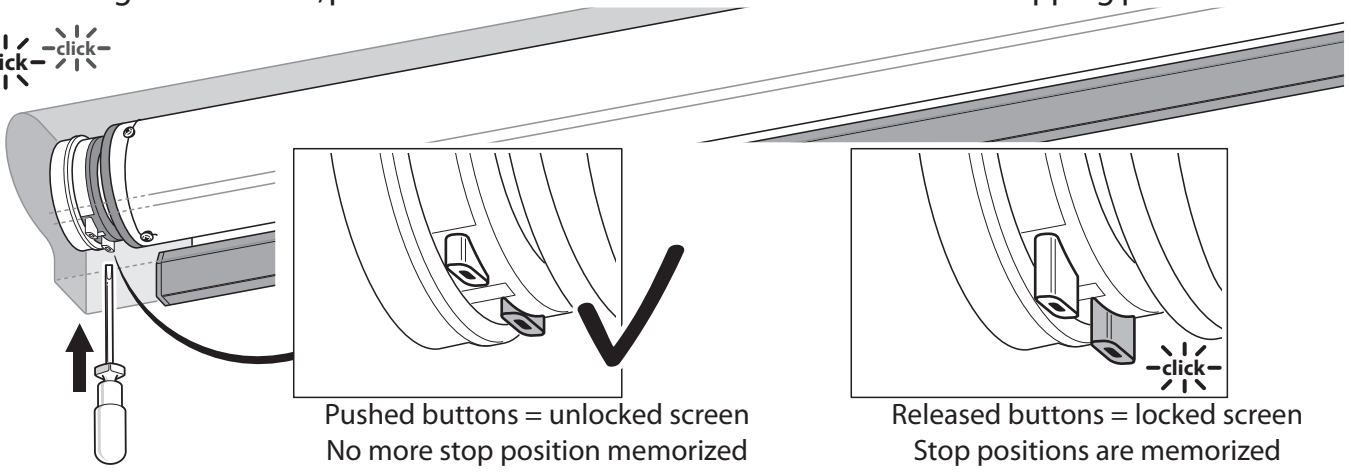

2 - Carefully deploy the screen to the desired position. Lock this position by releasing the correct button as shown in the table below.

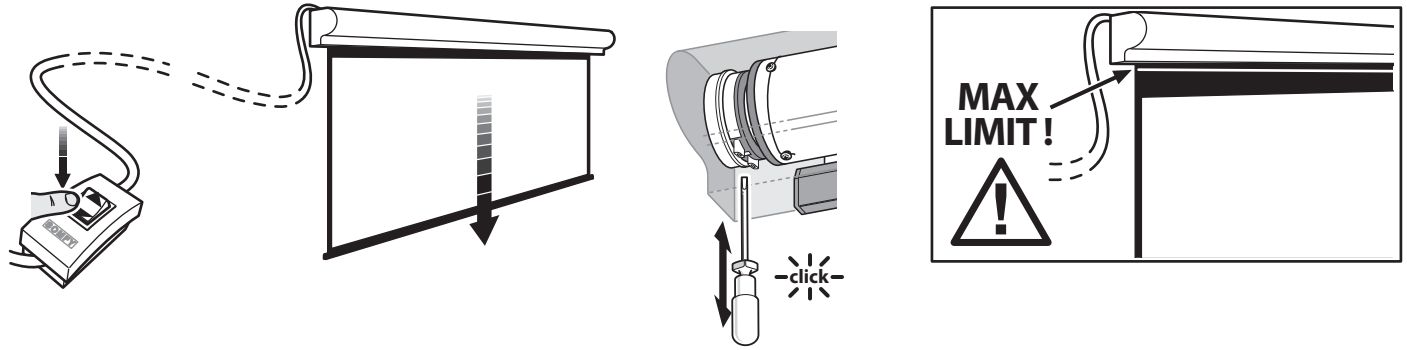

3 - Carefully define the desired closed position. Lock this position by releasing the correct button as shown in the table below.

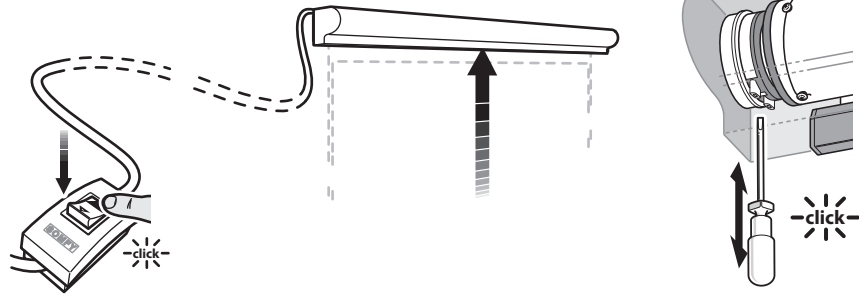

Refer to this table if the motor of your screen is mounted on the LEFT

Screen Model	Screen Lock UP	Screen Lock DOWN	Lateral Mask Lock UP	Lateral Mask Lock DOWN	Top Mask Lock UP	Top Mask Lock DOWN
MS2	yellow	white				
MMS2-L1	white	yellow	yellow	white		
MMS2-T	white	yellow			yellow	white
MMS2-L2	white	yellow	yellow	white	yellow	white
MMS2-4	white	yellow	yellow	white	yellow	white

Screen Research Product Warranty

1. LIMITED WARRANTY

Screen Research warrants the product designated herein to be free of manufacturing defects in material and workmanship, subject to the term and conditions hereinafter set forth.

Surface fabric(s) and frames are warranted for a period of five (5) years from the date of invoice by the original purchaser.

Motors, motor controllers, remote controls, and related assembly hardware are warranted for three (3) years parts and labor from date of invoice by the original purchaser.

2. CONDITIONS AND LIMITATIONS

This Warranty is subject to the following conditions and limitations. The Warranty is void and inapplicable if the product has been used or handled other than in accordance with the instructions in the owner's manual, abused or misused, damaged by accident or neglect or in being transported, or the defect is due to the product being repaired or tampered with by anyone other than Screen Research or an authorized Screen Research dealer or installer. The product must be installed by a professional, duly-authorized Screen Research dealer/custom installer, and maintained according to the written instructions.

3. RETURNS

No product returns accepted without a prior written return authorization from Screen Research.

Product must be packed in the original PACKAGE CONTENTS or equivalent packaging in order to avoid any damage during transportation. The product(s) must be packed and returned to Screen Research or an authorized Screen Research repair center by the customer at his or her sole expense. Screen Research will pay return freight of its choice.

A RETURNED PRODUCT MUST BE ACCOMPANIED BY A WRITTEN DESCRIPTION OF THE DEFECT AND A PHOTOCOPY OF THE ORIGINAL PURCHASE RECEIPT. This receipt must clearly list model and serial number, the date of purchase, the name and address of the purchaser and authorized dealer and the price paid by the purchaser. Screen Research reserves the right to modify the design of any product without obligation to purchasers of previously manufactured products and to change the prices or specifications of any product without notice or obligation to any person.

4. REMEDY

In the event the product fails to meet the above Warranty, the purchaser's sole remedy under this Limited Warranty shall be to return the product to Screen Research or an authorized Screen Research service center where the defect will be rectified without charge for parts or labor, during the term of this Limited Warranty.

5. LIMITED TO ORIGINAL PURCHASER

This Warranty is for the sole benefit of the original purchaser of the covered product and shall not be transferred to a subsequent purchaser of the product.

6. MISCELLANEOUS

Any implied warranties relating to Screen Research products shall be limited to the duration of this warranty. The warranty does not extend to any incidental or consequential damages to the purchaser. Some states or countries do not allow limitations on how long an implied warranty lasts, or an exclusion or limitation of incidental or consequential damages, so the above limitations or exclusions may not apply to you. This Warranty gives you specific legal rights, and you may also have other rights which vary from state to state, or country to country.

7. WARRANTOR

Enquiries regarding the above Limited Warranty may be sent to the following address, specific to country where purchased:

- Purchases in North and South America:

Screen Research, 2021 Las Positas Court, Suite 147, Livermore, California 94551 USA

- Purchases in Europe, Asia, Middle East, Africa, India, Asia, Australia:

Screen Research, Parc d'Activité de Ragon - 16, rue Louis Pasteur - 44119 NANTES - Treillières - France

8. WARRANTY SUPPORT MANAGED BY AUTHORIZED DISTRIBUTORS

Screen Research has authorized distribution in many countries of the world. In each country, the authorized importing Distributor is responsible for warranty support of products sold in the respective country by that retailer or distributor. Warranty service should be obtained from the importing retailer or distributor from whom you purchased your product. In the unlikely event of service required beyond the capability of the importer, Screen Research will fulfill the conditions of the warranty. No product returns will be accepted without a prior written return authorization from Screen Research. All product returns must be shipped at the owner's expense to the Screen Research factory, together with a photocopy of the bill of sale for that product, a detailed description of the problem, and any information necessary for return shipment.

Screen Research Contacts

Europe/ROW

Screen Research Worldwide

Parc d'activité Ragon
16 rue Louis Pasteur
44119 NANTES - Treillières
France

Tel: +33 (0)2 40 77 87 89
Fax: +33 (0)2 40 77 86 78

Email

To place an order.....orders@screenresearch.com
To obtain a quotation.....quote@screenresearch.com
To contact Customer Service.....customerservice@screenresearch.com
To contact Technical Support.....techsupport@screenresearch.com

North America

Screen Research USA

2021 Las Positas Court, Suite 147
Livermore, CA 94551
USA

Tel: +1 925 454 9900
Fax: +1 925 454 9904

Email

To place an order.....srsales@screenresearch.com
To obtain a quotation.....srsales@screenresearch.com
To contact Customer Service.....srsales@screenresearch.com
To contact Technical Support.....tech@screenresearch.com

Asia

Screen Research Asia

898/32B SV City 19th Fl. Office Tower
2 Rama III Road
Bangpongpang Yannawa
Bangkok 10120
Thailand

Tel: +66-(0)26 82 90 52
Fax: +66-(0)26 82 65 90

Email

ordersasia@screenresearch.com
quoteasia@screenresearch.com
customerserviceasia@screenresearch.com
techsupportasia@screenresearch.com

© Copyright 2009 Screen Research. All rights reserved.

Screen Research products are covered by one or more of the following patents:

No. 00 07372 (France); No. 6,552,847 B2 (USA); No. 04787296.5 (Europe) pending; No. 03 10375 (France); No. US-2008-0211972-A1 (USA) pending; No. PCT/FR04/02241 (International) pending; No. 200480025260.9 (China) pending; No. 1126/CHGENP/2006 (India) pending; No. 2006-524397 (Japan) pending; No. 04787296.5-2217 (United Kingdom) pending; No. 0409574 (France) pending; No. PCT/IB05/003917 (International) pending; No. 05817119.0-1252 (Europe) pending; No. 08.02361 (France) pending; No. 08/05836 (France) pending; No. 03 07216 (France); No. 10/557 781 (USA) pending; No. 04742791.9 (Europe) pending; No. 6,785,047 (USA)

ClearPix, ClearPix2, SolidPix, SolidPix1, GrayPix, X-Mask, C-Mask, LeWing, TheaterCurve, Pi-Grip, FastGrip, TFX, StopLight, DécorMask, TailorMade and the Screen Research logo are all trademarks of Screen Research.

All other trademarks are the property of their respective owners.